

Installation Manual Frequency Converter FM-2D/K

Pulse-current converter with integrated LC-Display

1. Description
2. Installation
3. Electrical connection
4. Connection examples
5. Programming and display
 - 5.1 Menu description
 - 5.2 Menu structure
 - 5.3 Programming
 - 5.4 Pulsers
 - 5.5 Factory settings
6. Limit points
7. M-Bus output
8. Surge / lightning protection
9. Maintenance / Troubleshooting
10. Exchanging fuses

1. Description

The FM-2D/K is a microprocessor controlled frequency converter with integrated display for programming and flow values. It transforms input pulses of one or two meters into proportional current for flow indication. The pulses are converted to:

- Standardised current (0/4 ... 20mA)
- Pulse totalisation
- M-Bus data protocol
- LC-Display values

2. Installation

- Top hat rail mounting
- Wall mounting

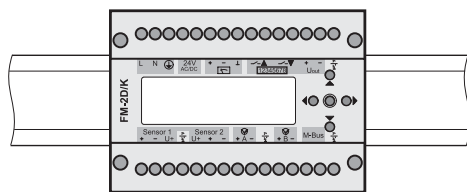

Snap action on 35 mm top hat rail acc. to EN 50022

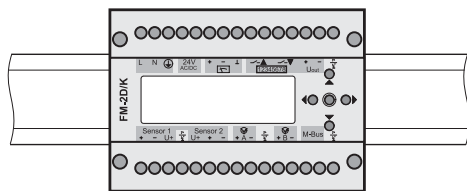

remove from top hat rail
(with a screw driver)

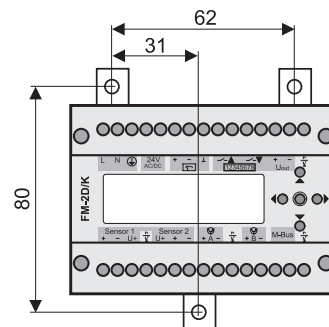

Wall mounting with 3 screws
without dismantling of housing

3. Electrical connection

The electrical installation has to be done by a specialist in accordance to the common safety standards. It must not be installed with power switched on.

Installation notice:

- Max. cable cross section 2.5mm²
- Always connect an Earth/Ground, even when using 24V
- Check voltage before connecting
- With 24V AC or DC power supply the polarity is irrelevant
- Please see data sheet LS 5200 INT for technical data
- Shielded cable is recommended for the signal in and outputs
- The shield must be connected to the corresponding terminals and Ground

* when cable length exceeds 3m we recommend using shielded cable for all signal input and outputs

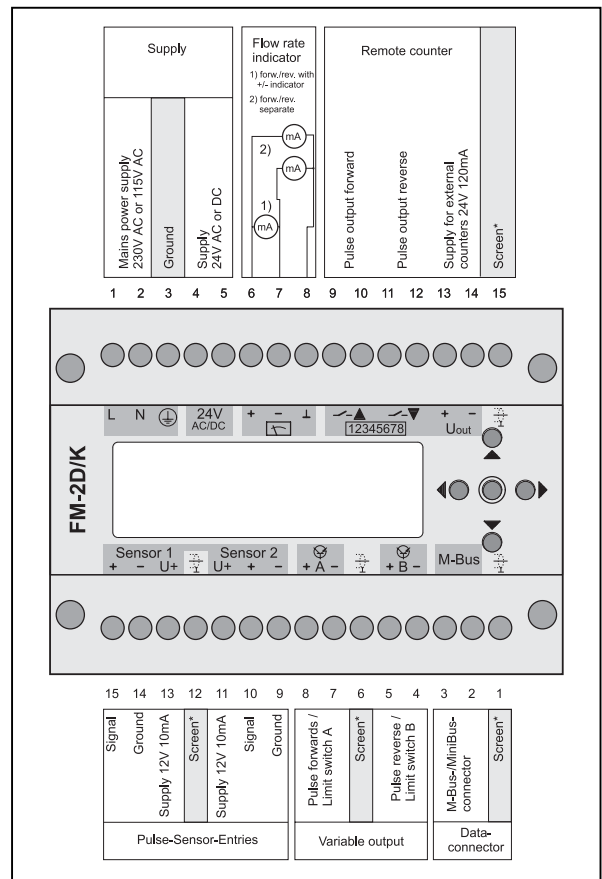

Terminal description			
Upper terminals (from left to right)		Lower terminals (from right to left)	
1	Mains power input 115/230V	1	Screen / Shield
2	Mains power input 115/230V	2	M-Bus / MiniBus output
3	Ground / Earth	3	M-Bus / MiniBus output
4	24V AC/DC power supply input	4	Open Collector output for flow direction signal or limit switch B
5	24V AC/DC power supply input	5	Open Collector output for flow direction signal or limit switch B
6	Current output 0/4-20mA Forward flow	6	Screen / Shield
7	Current output 0/4-20mA Reverse flow	7	Open Collector output for flow direction signal or limit switch A
8	Current output 0/4-20mA Common	8	Open Collector output for flow direction signal or limit switch A
9	Pulse output forward flow	9	Pulse input Sensor 2 Common
10	Pulse output forward flow	10	Pulse input Sensor 2 Signal
11	Pulse output reverse flow	11	Power supply output +12V 10mA for Sensor 2
12	Pulse output reverse flow	12	Screen / Shield
13	Power supply output + ; for electromechanical remote counters; 24V 120mA	13	Power supply output +12V 10mA for Sensor 1
14	Power supply output - ; for electromechanical remote counters; 24V 120mA	14	Pulse input Sensor 1 Common
15	Screen / Shield	15	Pulse input Sensor 1 Signal

4. Connection examples

Example 1 (default setting)

Connection of a combination watermeter, flowrate indicator and a passive 24V-remote counter

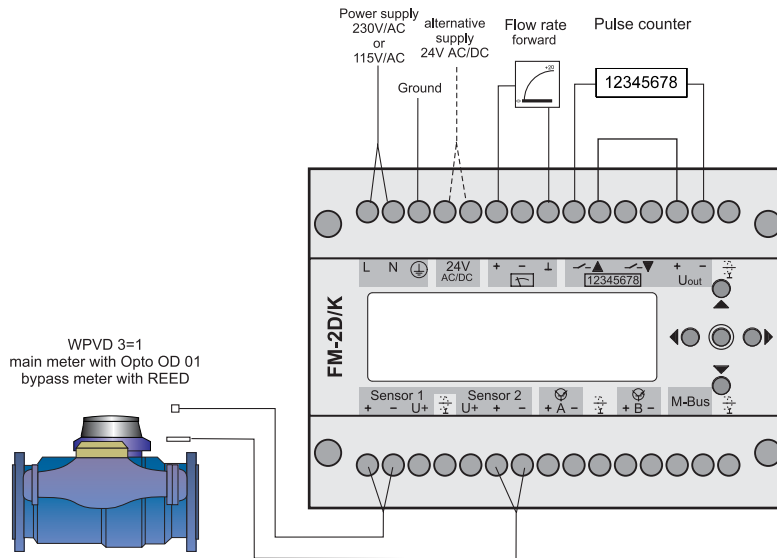

Note: There can be no reverse flow with a combination meter due to the built in non-return valves and ratchet in the register. If an HRI pulser is used on the bypass meter the type A1 should be used.

Example 2

Connection to 2 water meters with forward/reverse flow, 2 flowrate indicators, balance counter and inductive MiniPad.

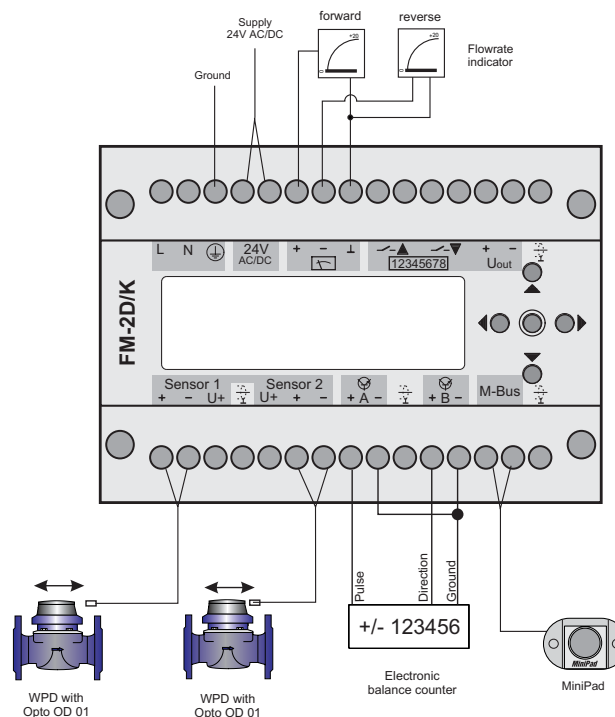

Example 3

Connection to a water meter with forward / reverse flow, 1 flowrate indicator, 2 remote counters, limit switch and electrical M-Bus.

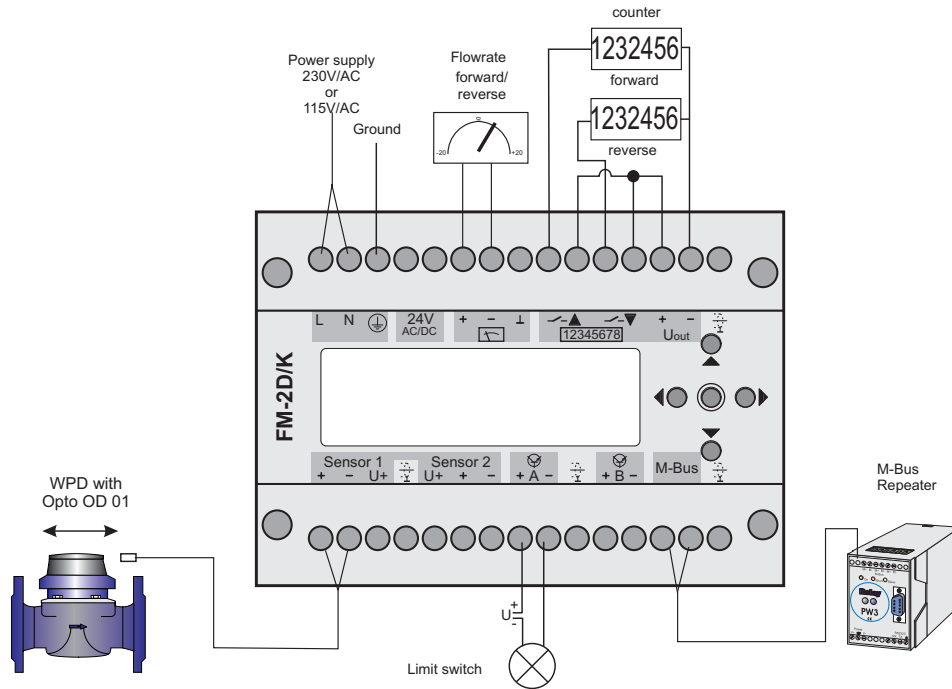

Example 4

Connection to a water meter with forward / reverse flow, a SPC or PLC system with current and pulse input and 2 limit switches.

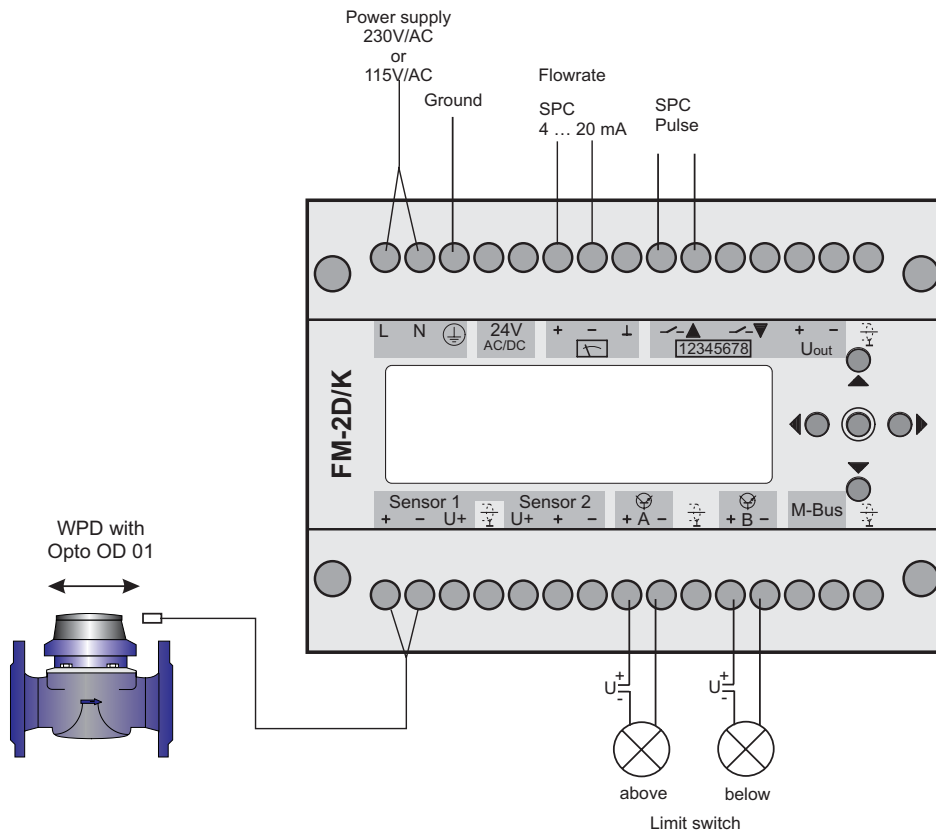

5. Programming and Display









5.1. Menu description



















The menu structure of the FM-2D/K has 4 loops, which are assigned with symbols.

By pressing the 5 buttons the user can move through the menu. The menu loops are rotating. The particular menu function is displayed as a symbol in the status line (bottom line) of the LC-display.

In the right hand side of the display up to 5 dots are displayed, indicating which buttons are active and can be pressed to navigate through the menu. The buttons have the following functions:

top	move one loop above / change a digit or a parameter
bottom	move one loop below / change a digit or a parameter
left	within a loop move one function ahead / within a menu function move one digit/parameter
ahead	
right	within a loop move one function back / within a menu function move one digit/parameter back
middle	open a menu function for changing or storing parameters

Symbols	
	 Loop programming
	 Loop reading of programming values
	 Loop reading of meter values
	 Loop reading of statistics values

Symbols of status line (bottom line)	
A	Loop programming
B	Loop reading programming data
C	Loop reading meter values
D	Loop statistics values
	Programming data stored
	Programming data can be changed
Σ	Summation of pulse inputs
Δ	Subtraction of pulse inputs
E Π	Choice of sensor type
E1 = Π	Pulse value sensor 1
E2 = Π	Pulse value sensor 2
+  - 100	Qmax (corresponds to 20mA)
+  -  ...	Current output and damping
 \square	Limit switches and hysteresis
 = Π	Pulse value Open collector output
0 = 	Start index
 = Π	Pulse value and status of relais output
K = ?	Open collector output
Test	Test mode
+  - 	Reading balanced volume and current flowrate
	Reading balanced volume
+  -	Reading current flowrate
R 	Reading reverse volume
+  - \uparrow	Extreme value Maximum (resetable)
+  - \downarrow	Extreme value Minimum (resetable)
+  - \uparrow 1	Extreme value Maximum 3 hour value
+  - \downarrow 1	Extreme value Minimum 3 hour value
\times	upper limit is passed
\times	lower limit is passed
\times	current value is within the limits
	Display of active buttons

5.2. Menu structure

Menu structure FM-2D/K

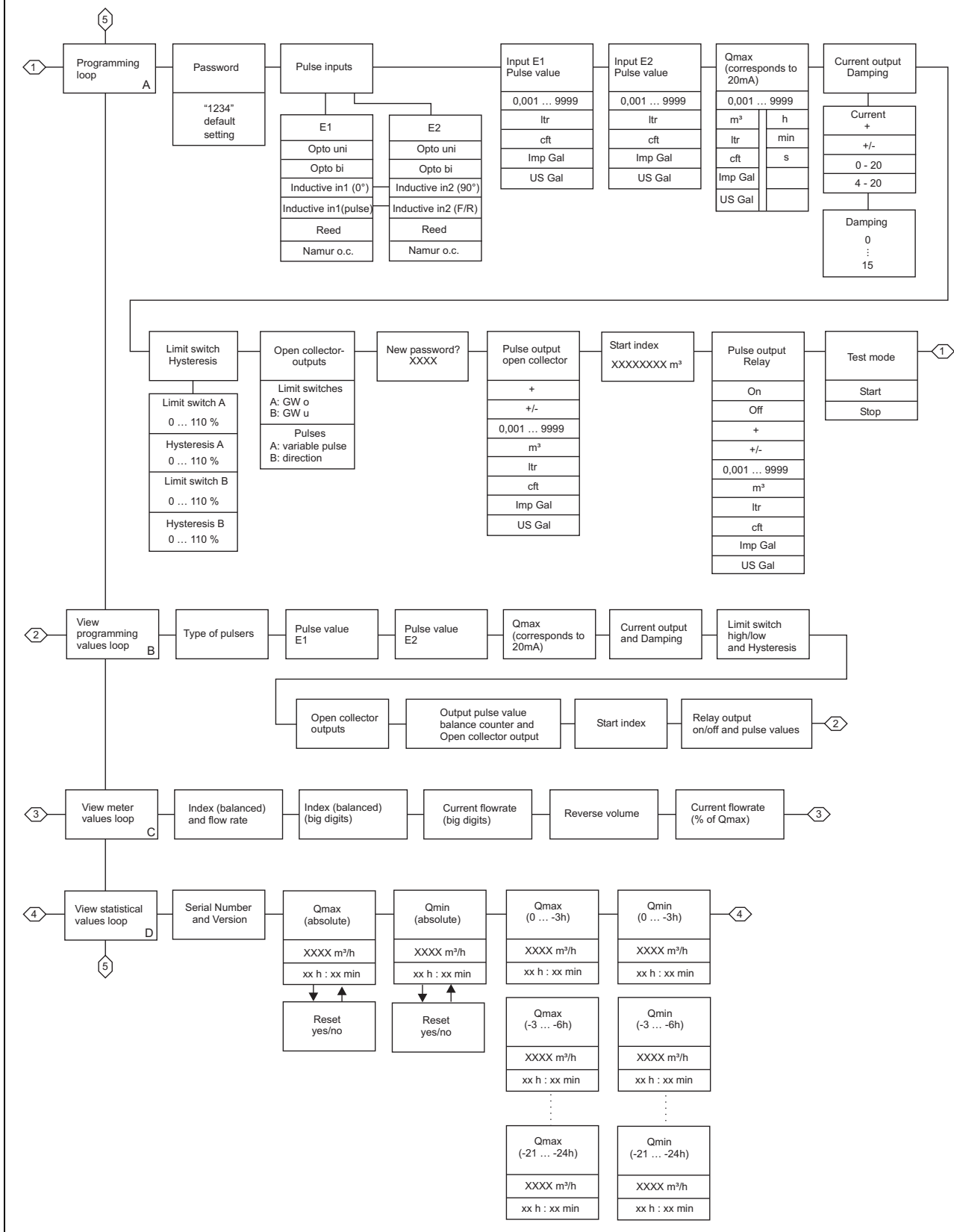

Notice: The time data displayed in the statistics loop are based on the time of reading, e.g.: if the time of reading is 8:00 am and the FM-2D/K displays 02h:45 min. This means time of the event was 5:15 am.

5.3. Programming

All parameters of the FM-2D/K are freely programmable. In loop A the programming is done. After entering the password (factory setting: 1234) the programming may be done. By pressing the middle button the lock for programming of the first menu function is opened. All possible settings are listed in the menu. By pressing the middle button again the changed parameters are stored. Pressing the right button moves to the next parameter. The following parameters must be set:

- Type of pulser, combination of sensors and input pulse value
- Qmax (value, which corresponds to 20mA, full-scale)

Once these settings have been entered the FM-2D/K is ready for operation. All further settings only have to be setup, if the particular function is used.

Notice:

- The unit chosen for the open collector output and position of the decimal point is used also for the internal display of volumes.

Example:

Open collector output: 00.01 m³ Display: XXXXXX.XX m³

- The Input types and the Pulser description:

Input type	Pulser description
Opto uni	Sensus pulser OPTO 01-04 or OD 01-04 (totalisation only in one direction) DIN 19234
Opto bi	Sensus pulser OPTO 01-04 or OD 01-04 (totalisation forward / reverse) DIN 19234
In1 0° / In2 90°	Pulser with 2 inductive probes with 90° offset signal for forward/reverse totalisation eg. Sensus pulser K07/08/11/12
In1 puls / In2 VR_	Pulser with 2 channels, channel 1 for pulses channel 2 for direction signal (contact open = forward, contact closed = reverse)
Reed	Potential free contact (Reed or relay)
Namur o.c.	All pulsers that conform to DIN 19234 or open collector pulsers.

Under 'Pulse inputs' between E1 and E2 a "+" or "-" can be set. This indicates the type of channel combination, "+" means both channels will be added together, "-" means that E2 will be subtracted from E1

5.4. Pulsers

Pulser	Terminal (Bottom row)	FM-2D/K setting
Relay contact or Reed pulser eg. RD 01; RD 02; REED 01; REED 02; K01; K02	14/15 or 9/10	Reed
Sensus optical pulser with flow direction recognition . OD 01 ... 04; OPTO 01 ... 04	14/15 or 9/10	Opto bi
Sensus optical pulser with flow direction recognition but with reverse pulse suppression eg. OD AM	14/15 or 9/10	Opto uni
Sensus Inductive pulser eg. K06; K10	14/15 or 9/10	Namur o.c.
Sensus Inductive pulser eg. K08; K12	Sensor 1: 14/15; Sensor 2: 9/10	induktiv 0°/90°
Sensus Inductive pulser HRI Type A2 (One forward and one reverse pulse output)	14/15 and 9/10	Namur o.c.
Sensus Inductive pulser HRI Type A1 (balanced forward pulses) The type A1 should be used for combination meters if the bypass meter of a combination meter has an HRI output and the main meter uses an optical or reed pulser.	14/15 or 9/10	Namur o.c.
Pulser that conforms to DIN 19234 Open Collector outputs	14/15 or 9/10	Namur o.c.
3-wire Pulser*	U+: 13 ; pulse: 14/15 or U+: 11; pulse 9/10	Namur o.c.

* with 3-wire pulsers, the transistor output must switch to earth / ground

MiniBus Readout values: Serial number of FM-2D/K
Current balanced volume

8. Surge / lightning protection

In high lightning / surge risk areas or using long cables the following over-voltage protection is recommended:

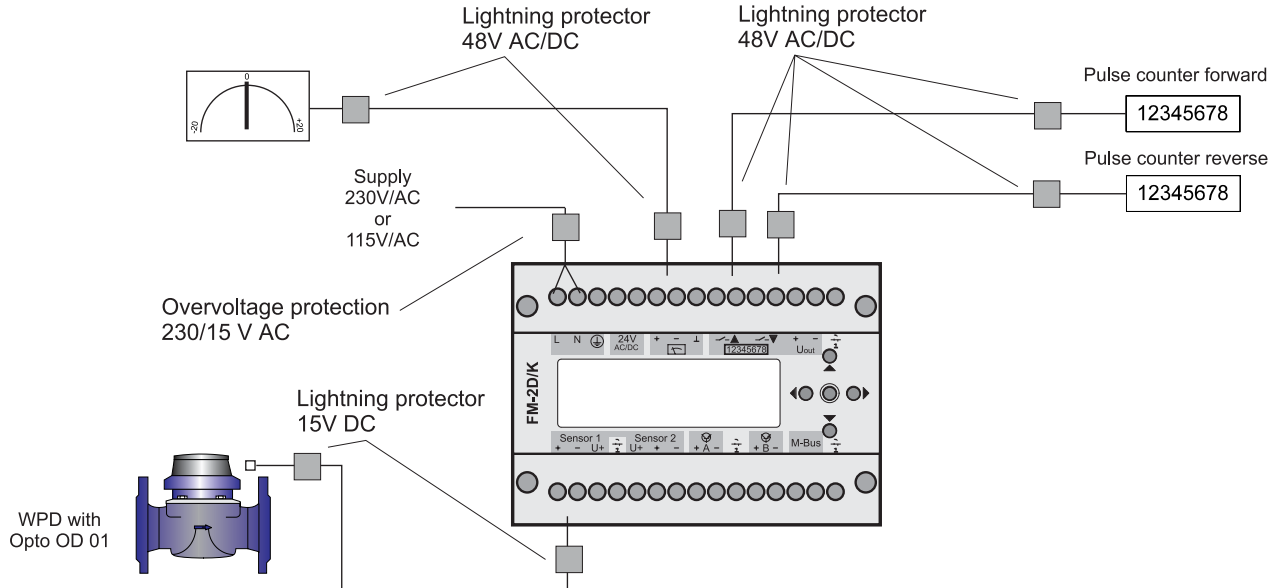

9. Maintenance / Troubleshooting

The FM-2D/K operates without any necessity of maintenance. The table below shows a selection of possible errors and their elimination.

Error symptom	Cause	Remedy
LC display is not working	Power supply failure	<ol style="list-style-type: none"> 1. Check supply voltage 2. if 230V: check internal voltage selector and fuse F 921 3. if 24 V: check fuse F922 and replace if fused
No current output Display indicates a flowrate	Break in the current output circuit	<ol style="list-style-type: none"> 1. Check cable connection 2. Check current output using the test mode 3. Check the connected indicator 4. Check fuse F 38 and replace if fused
No pulse output but internal display counts the volume	Break in the pulse output circuit	<ol style="list-style-type: none"> 1. Check cable connection 2. Check pulse output using the test mode 3. Check the external totaliser and its power supply 4. Check fuse F 99
	Relay output is set as "off"	Activate the relay pulse output
Flowrate display "0" and no output pulses but the water meter is working and the pulser is connected	Break in the pulse input circuit	<ol style="list-style-type: none"> 1. Check the settings of FM-2D/K 2. Disconnect the pulser, set the pulser to 'Reed o.c.' and repeatedly short-circuit the sensor terminals (+) and (-) with a wire or paperclip. DO NOT SHORT-CIRCUIT THE POWER SUPPLY!! - If then flowrate is displayed: replace pulser - If not: check fuses F 18, F111 and F121
FM-2D/K refuses programming	<ol style="list-style-type: none"> 1. Wrong parameters 2. The wrong password has been entered 	<ol style="list-style-type: none"> 1. Check parameters 2. Check password
Display shows "over"	The input frequency is above 1kHz. Possibly due to a contact bounce of a reed switch	<ol style="list-style-type: none"> 1. Check settings (increase Qmax and check pulse value) 2. Exchange pulser (Opto or inductive) 3. Use contact protection relay to prevent bounce

Exchanging fuses is described in section 10 of this manual.

10. Exchanging fuses

The Inputs and outputs of the FM-2D/K are protected against damage by fuses. Exchanging the fuses is done as follows:

- Disconnect the FM-2D/K from power supply
- unscrew the 4 screws at the front of the device
- remove electrical connection terminals above and below (wires can be connected)
- remove housing from top hat rail
- remove display and printed circuit boards from the housing
- open the fuse holder, check fuse and change the fuse if necessary
- assemble the device in reverse order

Size of fuses

Supply board

F 38	fuse 32mA	medium	current output
F 99	fuse 315mA	medium	output supply circuit
F 921	fuse 630mA	medium	secondary supply (internal)
F 922	fuse 630mA	medium	24V supply (external)
F 91	fuse 100mA	slow	mains power supply (primary)

Processor board

F 111	fuse 32mA	medium	input circuit sensor 1
F 18	fuse 32mA	medium	12V supply for sensors
F 121	fuse 32mA	medium	input circuit sensor 2

Layout of fuses

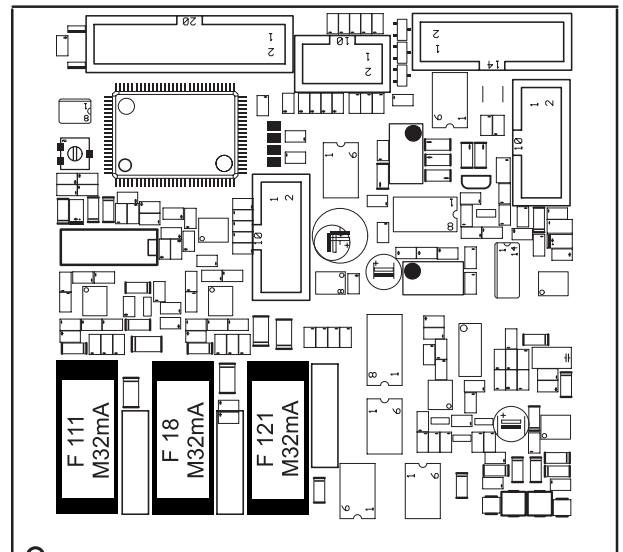
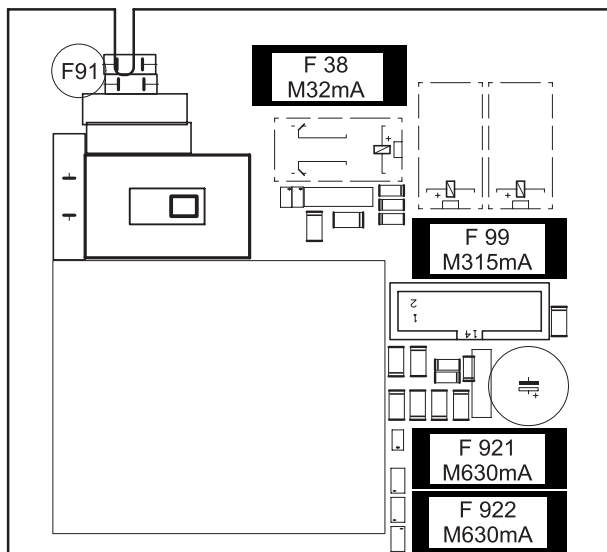

edition 14.10.2004